

**Warewashing**  
**Flight type dishwasher, 1 tank, 5200**  
**dishes/h, electric, 1100mm loading,**  
**2200mm unloading, 1dryer,ES**

ITEM # \_\_\_\_\_

MODEL # \_\_\_\_\_

NAME # \_\_\_\_\_

SIS # \_\_\_\_\_

AIA # \_\_\_\_\_



**520141**  
**(EFTD052EL3U5DIM5ER385)** Flight type dishwasher, 1 tank, 5200 dishes/h, electric, 1100mm loading, 2200mm unloading, 1 dryer, 75mm conveyor, ESD, right to left

### Short Form Specification

**Item No.** \_\_\_\_\_

Unit to be Electrolux flight type dishwasher. Operating direction right to left. Electric heated. Featured built-in Energy Saving Device (ESD) recovers the heat inside the machine to heat up incoming cold water to the boiler. Powerful wash pump and specially designed wash spray arms to guarantee cleaning. Unit to feature 800 mm DUO rinse area with curtain-spray pattern duo rinse arms and pre-adjustable pressure valve providing constant rinsing pressure for optimum rinsing result. Unit to feature as standard 800mm drying tunnel allowing washed dishes practically dried immediately. Washing is carried out with water circulating at a temperature of 55-65 °C. Rinsing is carried out with clean water coming from the water system, heated to a temperature of 82-90 °C. Unit to have two conveyor speeds which can be selected from the control panel by the operator. Unit to feature large double-skinned and counter-balanced doors for easy access of internal components. Large loading section (1100mm) and unloading section (2200mm) with automatic conveyor stop to facilitate the operation of the machine. Multi-purpose conveyor with 75mm finger distance.

### Main Features

- The water in the main wash tanks circulating at a temperature of 55-65°C is pumped with detergent and is sprayed over the items from both the upper and the lower wash arms, guaranteeing a uniform distribution of the washing solution and allowing all the areas of the washing chambers to be covered.
- Rinse area equipped with the DUO-rinse system: the first rinse arms with side nozzles are filled with re-circulated rinsed water then spray at powerful pressure in a curtain pattern to eliminate majority trace of detergent, while the second arms are filled with hot clean water at temperature of 82-90°C to guarantee the hygiene performance on the washed wares.
- Built-in pre-adjustable pressure valve before the boiler stabilizes incoming water pressure to ensure the proper rinsing pressure for optimum hygiene.
- A drying section with inspection door (800 mm length) is equipped as an integral part of the machine. This allows the operator to remove practically dried items immediately, without them being too hot to handle.
- Two conveyor speeds can be selected through the control panel by the operator.
- The multi-purpose conveyor belt with 55mm finger distance allows to load the tablewares either directly on the conveyor or using standard 500x500mm racks.
- The unloading section of 1.000mm with an end limit switch mounted at the end stops the conveyor automatically to avoid damaging clean items if not removed on time.
- The machine incorporates a safety switch for stop in urgency at both loading and unloading sections which will stop the conveyor by pushing the button in case that washed wares have not been removed after cleaning.
- Flat panel with simple to use control and all temperature displays.
- Adjustable feet for full access underneath the machine for cleaning.
- Maximum capacity per hour of 5.200 dishes.
- The large loading section of 1100mm facilitates the loading of tablewares.
- Simple service from the front.

### Construction

- All main components made in heavy duty anti-corrosive 304 type stainless steel: external front, side, back panels and internal chamber, wash and arms, tank filters, doors.
- Deep drawn pressed tanks with fully round corners to prevent dirt build up provides fast drainage. Pressed tanks with no welded points offer a guaranteed water tight solution.
- No leg in loading area.
- Double tank filters (flat and small strainer) cover the entire width of the tank.
- Wash/rinse arms and filters are easy to remove for cleaning.
- Drain line is fully enclosed with anti-corrosive 304

**APPROVAL:** \_\_\_\_\_

type stainless steel panels for easy and safe floor cleaning as well as avoid damaging the pipe during transportation.

### Sustainability



- Built-in Energy Saving Device (ESD) utilizes the hot steam generated by the machine in the rinse and wash tanks to heat up incoming cold water up to 55°C before entering the boiler, thus saving energy.
- Low water consumption saves energy, water, detergent and rinse aid. At maximum capacity, the machine uses only 210 liters/hour.
- IR photo sensors are incorporated at loading section to stop washing and rinsing soon when no wares loaded, thus effectively save energy, water, detergent and rinse aid.

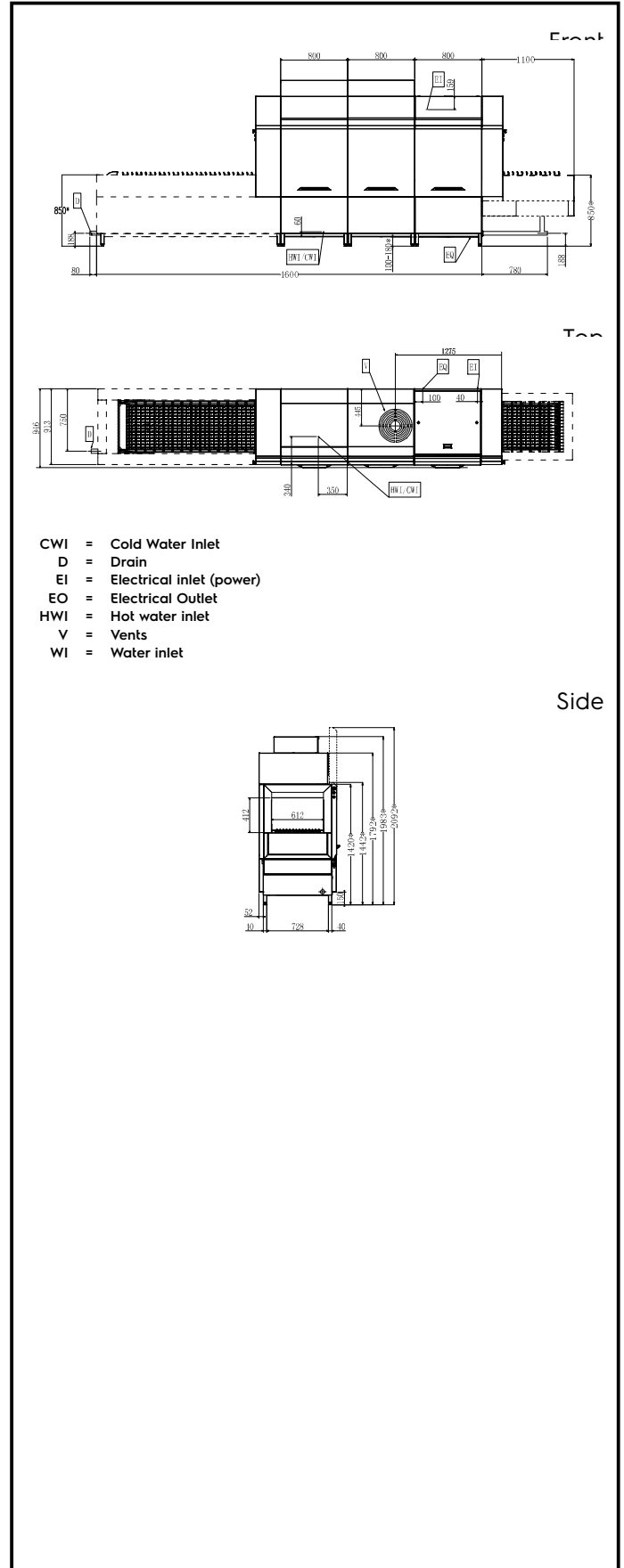
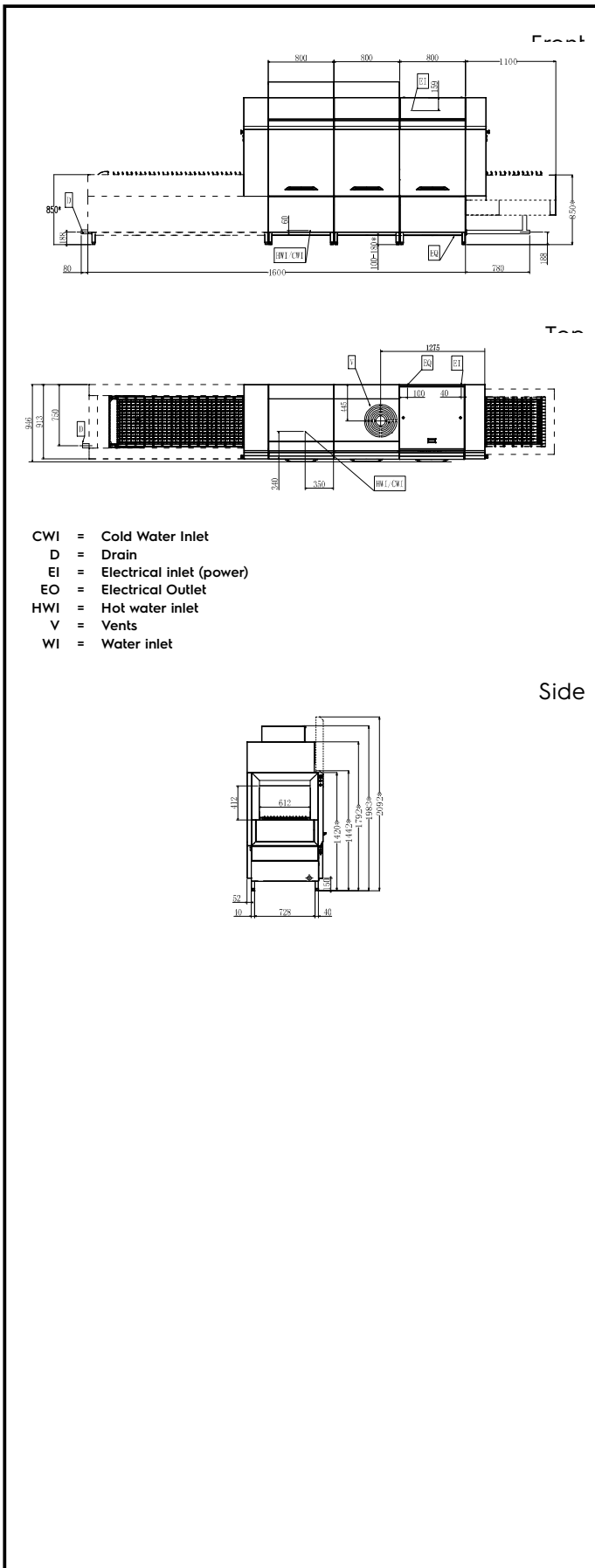

## Electric

### Supply voltage:

520141  
 (EFTD052EL3U5D1M5ER385) 380-415 V/3N ph/50 Hz

Default Installed Power: 42.7 kW

Wash tank heating elements: 16 kW

Boiler heating elements: 14 kW

Dryer install power: 9.75 kW

Rinse pump size: 0.25 kW

Wash pump size: 2 kW

## Water:

Inlet water line size: ISO 3/4" G

Drain line size: 2"

Inlet water supply pressure: 1-6 bar

Inlet water supply temperature  
 (boiler): 10 min / 30 max °C

Inlet water supply temperature  
 (tanks): 10 min / 60 max °C

The higher the temperature, the faster the warm-up time.  
 Recommended temperature of 50°C.

Flow rate of wash pump: 560 l/m

Inlet water supply hardness  
 (min/max): 14 / 8 °fH/°dH

Wash tank size: 98 l

Duo rinse tank size: 6 l

## Key Information:

Productivity per hour (max  
 speed): 5200dishes/3477trays/193Basket

Productivity per hour (slow  
 speed): 3240dishes/2160trays/120Basket

Conveyor speed (min/max): 1 / 1.6

Duo rinse temperature:

Final rinse temperature:

1st wash temperature:

Drying temperature: 50-70 °C

Drying fan capacity: 3500 m<sup>3</sup>/h

External dimensions, Width: 5700 mm

External dimensions, Depth: 946 mm

External dimensions, Height: 1983 mm

Height with door open: 2092 mm

Charging hole size (width): 612 mm

Charging hole size (height): 412 mm

Net weight: 1060 kg

## Air Emission:

Air Flow: 180 m<sup>3</sup>/h

Air temperature: 40 - 50 °C

Air humidity: 95%

The data is measured at exhaust points at 25°C and 60% r.h.  
 ambient conditions, 14°C inlet water temperature and refer only to  
 the machine.

## Sustainability

Rinse water consumption at  
 max. speed: 210 l/h